

Outdoor

ST.S145 / TUS.ST.S145

Typology: Suspension

Description Descripción

Acrylic ribbon shade suitable for outdoor use.
Acrylic ribbon available in different colors.
Opal half moon acrylic diffuser.
Black metal structure.
Black electrical cable.
Black canopy.

*Pantalla de cinta acrílica para exterior.
Cinta acrílica disponible en varios colores.
Difusor semiesférico de metacrilato opal.
Estructura metálica negra.
Cable eléctrico y florón negro.*

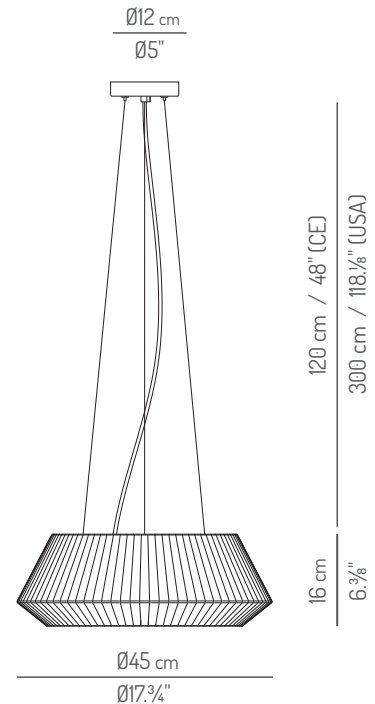

Light Source Fuente de luz

Voltage Voltaje 220-230V / 50-60Hz
120V / 60Hz (USA)

European version

ST.S145.16



LED 15W 230V 2700K 1200lm
Dimmable TRIAC



USA version

TUS.ST.S145.16



LED 10W 120V 2700K 880lm
Dimmable TRIAC

Module LED included / Módulo LED incluido



Packaging Embalaje

1 box

53x53x35 cm / 0,0983 m³
21"x21"x14" / 3,47 ft³

Peso bruto: 3 Kg
Gross Weight: 6,61 lb

Materials & Finishings Materiales y acabados

Acrylic ribbon shade
Pantalla de cinta acrílica



For available colors check general catalogue
Para colores disponibles, consultar catálogo general

Black metal canopy
Florón metálico negro

Black electrical cable
Cable eléctrico negro

Certifications:



USA Certifications:



Pending

Suitable for outdoor use / Apta para uso exterior

Outdoor

ST.S160 / TUS.ST.S160

Typology: Suspension

Description Descripción

Acrylic ribbon shade suitable for outdoor use.
 Acrylic ribbon available in different colors.
 Opal half moon acrylic diffuser.
 Black metal structure.
 Black electrical cable.
 Black canopy.

*Pantalla de cinta acrílica para exterior.
 Cinta acrílica disponible en varios colores.
 Difusor semiesférico de metacrilato opal.
 Estructura metálica negra.
 Cable eléctrico y florón negro.*

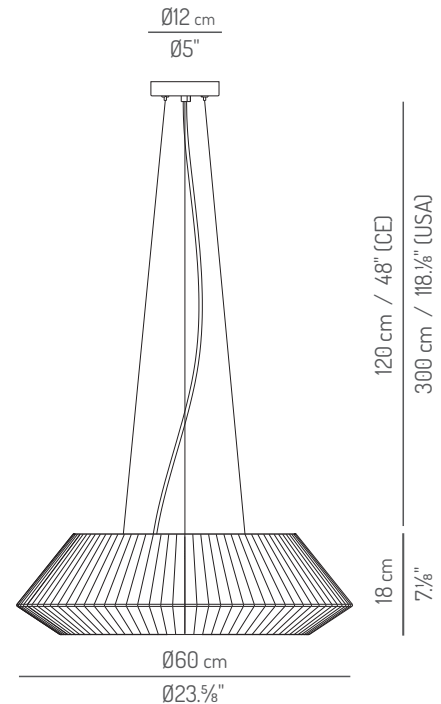

Light Source Fuente de luz

Voltage Voltaje 220-230V / 50-60Hz
 120V / 60Hz (USA)

European version

ST.S160.16



LED 15W 230V 2700K 1200lm
 Dimmable TRIAC



USA version

TUS.ST.S160.16



LED 10W 120V 2700K 880lm
 Dimmable TRIAC

Module LED included / Módulo LED incluido



Packaging Embalaje

1 box

64x64x35 cm / 0,143 m³
 25"x25"x14" / 5,05 ft³

Peso bruto: 5 Kg
 Gross Weight: 11 lb

Materials & Finishings Materiales y acabados

Acrylic ribbon shade
 Pantalla de cinta acrílica



For available colors check general catalogue
 Para colores disponibles, consultar catálogo general

Black metal canopy
 Florón metálico negro

Black electrical cable
 Cable eléctrico negro

Certifications:



USA Certifications:



Pending

Suitable for outdoor use / Apta para uso exterior